

POLO TMS

Bi-oriented metallized polypropylene film, moderate barrier and heat-sealable

MAIN CHARACTERISTICS

Metallized BOPP film with moderate barrier, non-treated, one side metallized and other side heat-sealable.

APPLICATIONS

Laminate structures for flexible packaging of biscuits, snacks, confectionery, ice-cream and general decorative applications.

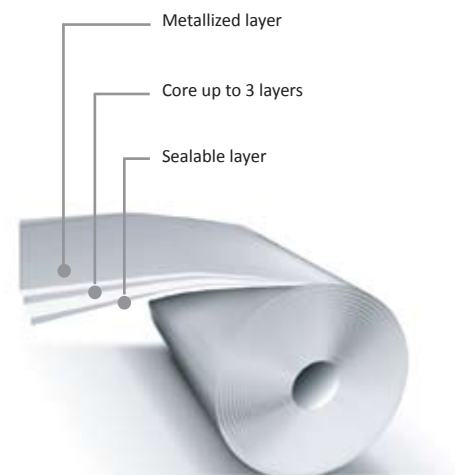

TYPICAL PROPERTIES

Characteristics	Methodology	Unit	15 TMS 10	17 TMS 10	20 TMS 10	25 TMS 10	30 TMS 10	50 TMS 10
Thickness	DIN 53370	gauge micron	60 15.0	65 17.0	80 20.0	100 25.0	120 30.0	200 50.0
Unit Weight	ASTM D 4321	lb/ream g/m ²	8.3 13.6	9.5 15.4	11.1 18.1	13.9 22.6	16.7 27.2	27.8 45.3
Yield	ASTM D 4321	in ² /lb m ² /kg	51800 73.7	45800 65.0	39000 55.2	31000 44.2	26000 36.8	15500 22.1
Light Transmission	ASTM D 1003	%	<1	<1	<1	<1	<1	<1
Tensile Strength	MD TD ASTM D 882	lbf/in ² N/mm ² lbf/in ² N/mm ²	20370 140 34920 240	20370 140 34920 240	20370 140 34920 240	20370 140 34920 240	20370 140 34920 240	20370 140 34920 240
Elongation at break	MD TD ASTM D 882	%	170 50	170 50	170 50	170 50	170 50	220 60
Sealing Range	Film/Film Untreated/Untreated ASTM F 88	°C °F	105-130 221-266	105-130 221-266	105-130 221-266	105-130 221-266	105-130 221-266	105-130 221-266
Sealing Strength	Film/Film Untreated/Untreated ASTM F 88	g/in	350	350	400	430	450	550
Shrinkage	MD TD ASTM D 1204	%	3 1	3 1	3 1	3 1	3 1	3 1
COF	Film/Film Untreated/Untreated ASTM D 1894	-	0.35	0.35	0.35	0.35	0.35	0.35
WVTR	73F/90%RH 38°C/90%RH ASTM F 1249	g H ₂ O/(100 in ² .24hs) g H ₂ O/(m ² .day)	0.04 ⁽¹⁾ 0.60 ⁽¹⁾	0.04 ⁽¹⁾ 0.60 ⁽¹⁾	0.03 ⁽¹⁾ 0.50 ⁽¹⁾	0.03 ⁽¹⁾ 0.50 ⁽¹⁾	0.03 ⁽¹⁾ 0.50 ⁽¹⁾	0.13 ⁽¹⁾ 2.0 ⁽¹⁾
OTR	73F/760 mm Hg 23°C / 1 atm ASTM D 3985	cc O ₂ /(100 sq in ² .24hs) cm O ₂ /(m ² .day)	7.71 ⁽¹⁾ 120 ⁽¹⁾	7.71 ⁽¹⁾ 120 ⁽¹⁾	6.43 ⁽¹⁾ 100 ⁽¹⁾	5.14 ⁽¹⁾ 80 ⁽¹⁾	5.14 ⁽¹⁾ 80 ⁽¹⁾	48.2 ⁽¹⁾ 750 ⁽¹⁾

(1) Typical values
OBS: Non sealed in he metallized face

SUPPLY SPECIFICATIONS

Width	0/+2 mm or 0/+ 0.08 inches from standard width
Outside diameter	- 30 mm or 1.18 inches from standard diameter + 20 mm or 0.8 inches from standard diameter
Core	Core: 153 mm or 6.0 inches / 77 mm or 3.0 inches Tolerance: ±1 mm or ± 0.04 inches
Number of splice per reel	Maximum 2
Percentage of splices per order	Maximum 30%

"The restrained information in this catalog represent typical data, and does not constitute genuine warranty liability as far as the product process and or application.
For new thicknesses or application , please consult a Polo Film's specialist".



Polo Indústria e Comércio Ltda. - Unigel
Phone: + 55 11 3478-5950 / Fax: + 55 11 3478-5999
e-mail: polofilms@polofilms.com.br
site: polofilms.net